

MODEL	Approved Ratings kW(hp) @ Rated speed rpm		
	1,470	1,760	2,100
DF12TiH-F	228 (310)	252 (343)	261 (355)

ENGINE SPECIFICATIONS	
· Engine Series	DOOSAN PU126TiH
· Engine Type	In-line 4 cycle, water cooled 6 cylinder
· Aspiration	Turbo charged & Intercooled
· Combustion Type	Direct injection
· Bore x Stroke	<i>mm (inch)</i> 123(4.84) x 155 (6.1)
· Compression ratio	17 : 1
· Displacement	<i>litre (inch³)</i> 11.051(674.5)
· Rotation	Anti-Clockwise
· Weight	<i>kg</i> 1023
· Valves lashes at cold	<i>mm (inch)</i> Intake 0.30 (0.0118) Exhaust 0.30 (0.0118)
· Wiring Diagram	No. 01.900.07EWEN.03
· Panel Diagram	No. 01.900.07PDEN.03
· Oil pan capacity	<i>litre (gal.)</i> High level 23 (6.1) Low level 20 (5.3)
· Battery Capacity	<i>Ah</i> 150 recommend (<i>battery not incl.</i>)
· Coolant capacity	<i>litre (gal.)</i> 26 (6.9)

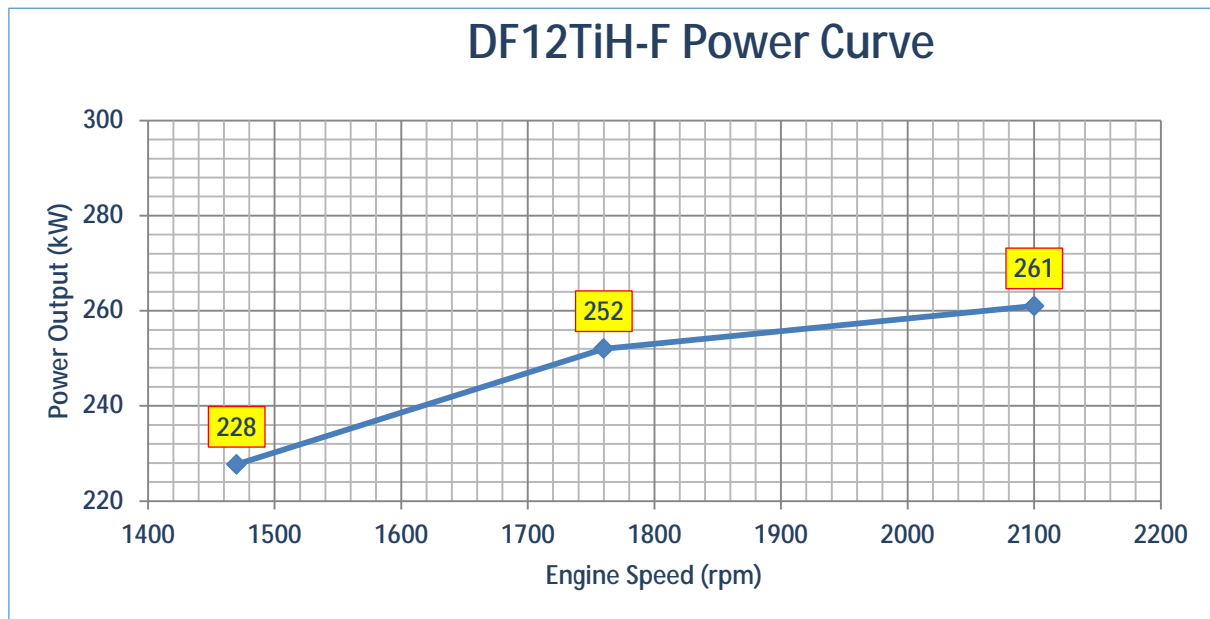
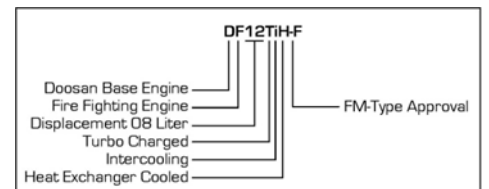
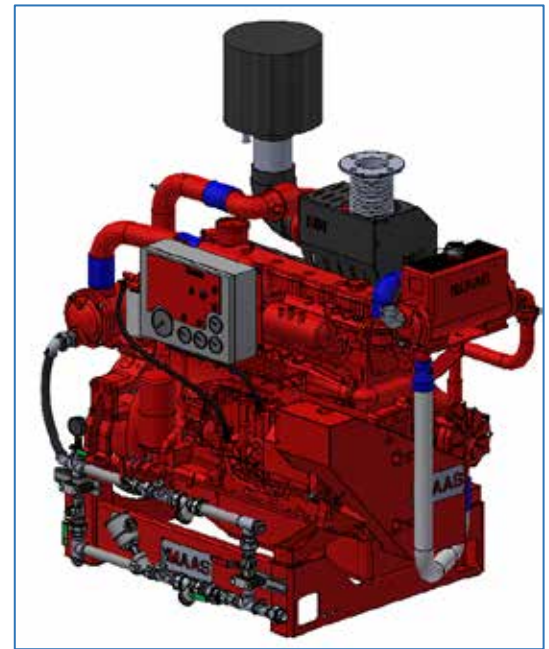

Although our FM ratings are shown at specific speeds, De Maas FFE engines can be applied at any intermediate speed. To determine the intermediate speed power; make a linear interpolation from the applicable De Maas power curves.

ENGINE RATINGS BASELINES

Engines are not to be used for continuous duty. Engines are to be used only for stationary emergency standby fire pump service. According to NFPA 25 engines are to be tested 30 minutes per week at no pump flow and full pump flow once per year.

Engines are rated at standard SAE conditions of 29.61 in. (7,521 mm) Hg barometer and 77°F (25°C) inlet temperature (approximates 300ft. (91.4m) above sea level) by the testing laboratory (see SAE Standard J1349).

A deduction of 3 percent from engine horsepower rating at standard SAE conditions shall be made for diesel engines for each 1,000ft. (305m) altitude above 300ft. (91.4m).

A deduction of 1 percent from engine horsepower rating as corrected to standard SAE conditions shall be made for diesel engines for every 10°F (5.6°C) above 77°F (25°C) ambient temperature.

Restricted: Use ratings only for stand-by fire pump applications

Copyright and ownership of this Power Curve is vested in De Maas B.V., whose prior written consent is required for its use, reproduction or for publication to any third party. All rights reserved.

Tested at standard SAE conditions of 29.61 in. (7,521 mm) Hg barometer and 77°F (25°C) inlet temperature (approximates 300ft. (91.4m) above sea level) by the testing laboratory (see SAE Standard J1349). Used Diesel fuel ASTM 2D.

Engine Equipment	Standard	Optional
Air cleaner	Drip proof, disposable	
Alternator	24 Volts x 45 Amps with belt guard	
Exhaust protection	Sheet steel Guarding	PIPE MATRASSES ONLY
Exhaust flex connection <i>mm (inch)</i>	113.0 (4")	
Flywheel housing	SAE 1	DRIVE LINE
Flywheel connection	SAE 14	STUB SHAFT
Fuel filter	Full flow, cartridge type	
Fuel Lines	Flexible hoses according ISO 15540	
Engine heater	24 Volts 3,000 Watt	
Governor speed	Constant speed, mechanical	
Heat exchanger	Tube Stack Type	
Control / Instrument panel	Build on Engine	OPTIONS ON REQUEST
Junction box	Integrated in control panel with instrument panel	
Lube Oil filter	Full flow, cartridge type	
Lube Oil pump	Gear type, driven by crankshaft	
Manual start	On instrument panel	
Overspeed control	Electronic instrument panel, test on instrument panel	
Run-stop control	On instrument panel	
Starters	24 Volts x 6 kW	
Throttle Control	Adjustable speed control,	
Water pump	Centrifugal type driven by gear	
Mountings	Industrial type	PEDESTAL MOUNTING ON REQUEST

